



# **Epson 12000XL**

## **Scanner**

## Using the Scanner

### Scanning Photographs

#### Step 1: Prepare scanner

- Put on gloves. This way you won't leave prints on your photographs and scanner.
- Gently lift the scanner's lid.
- Clean the scanner's surface with an anti-static cloth and air puffer.



#### Step 2: Prepare photographs

Note: Make sure the Transparency Unit Mat is in place, there should be a white mat attached to the inside of the scanner's lid. If it is not there, please ask the Memory Lab volunteer for assistance.

- Pick up your photographs by the edges and use the air puffer to remove any dust.
- Place photographs face-down on the scanning bed. You can scan multiple photographs at once.
- Be careful not to scratch the scanning bed.
- Carefully close the scanning bed lid.



#### Step 3: Open Epson Scan

- Make sure that the scanner is powered on.
- Connect your **flash drive** or **external hard drive** to the computer by USB or USB-C.
- Open **Epson Scan icon** located on the desktop.

## Step 4: Settings

- Make sure the “Mode” is set to **Photo Mode**
- Set the “Document Source” to **Scanner Glass**
- Set the “Document Type” to **Reflective**
- You can decide other setting as you prefer. If you are not sure, we recommend the following:
  - Image type: **24-bit color**
  - Resolution: at least **600** for photos
  - Scanning Quality: **Standard**
  - Image Format: **TIFF** (for archival quality; better for printing and editing) or **JPEG** (for sharing online)

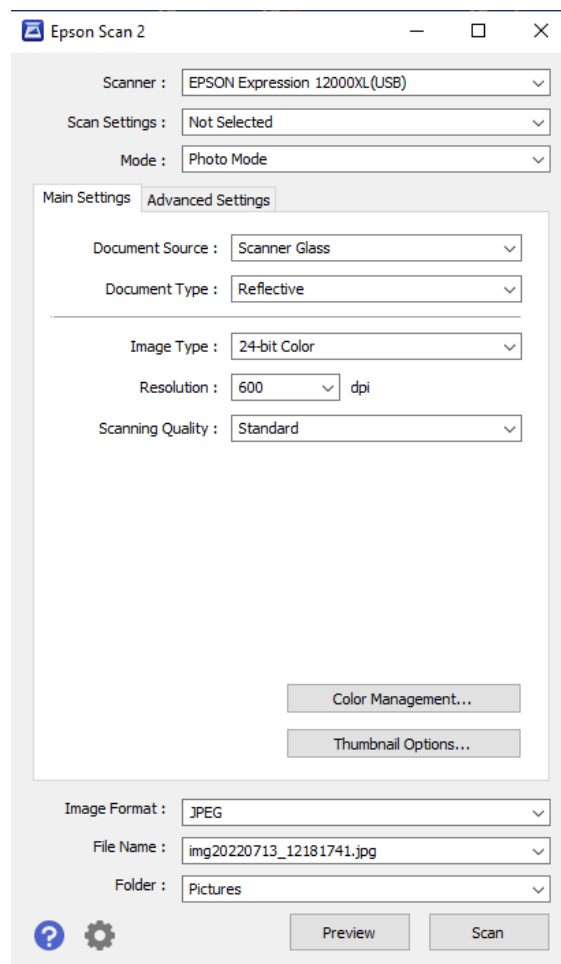

## Step 5: File Settings

- Click on the **File Name** dropdown list and click **Settings**

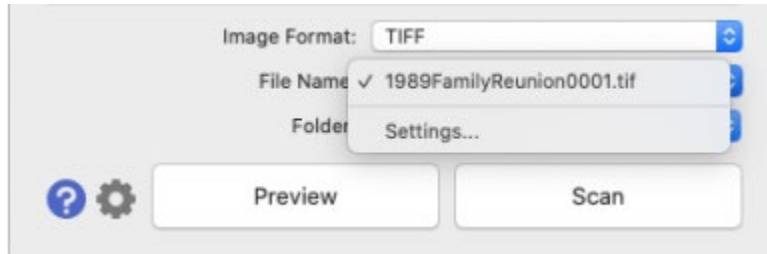

- In the **Prefix** box, type your file name. This name will be used for all the photographs scanned in a single batch, with each one followed by a unique number. You can choose the **Number of Characters** that will appear in each number.
- Click **OK** when finished.

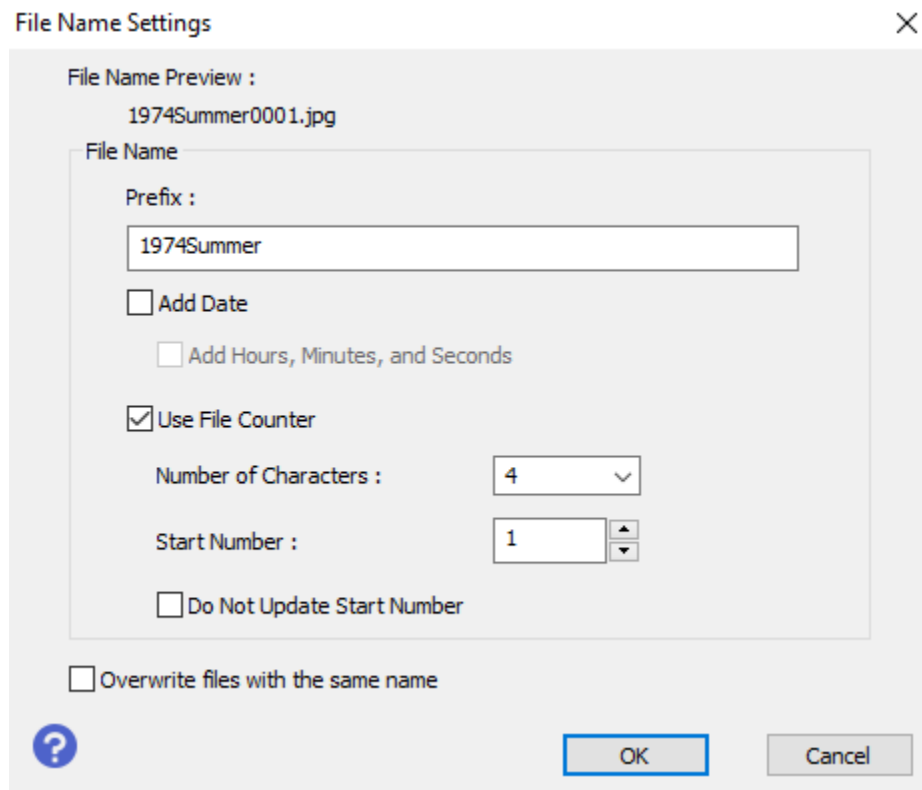

- Click on the **Folder** drop down menu and choose **Select** to find your hard drive or Flash drive from the list. If you are using cloud storage, choose “Desktop”.

## Step 6: Preview and scan

- Click **Preview** button at the bottom of the main setting window. The scanner should automatically recognize your photographs as separate files. If it does not, make sure that the **Thumbnail** setting at the top is selected and click **Preview** again.
- You can use the icons on the left side of the window to rotate or flip each image that you select.



- When finished previewing, click **Scan** at the bottom of the main settings window.

## Step 7: Add metadata to your files (optional)

- Right-click on one of your finished files and select **Properties** as shown on the next page.

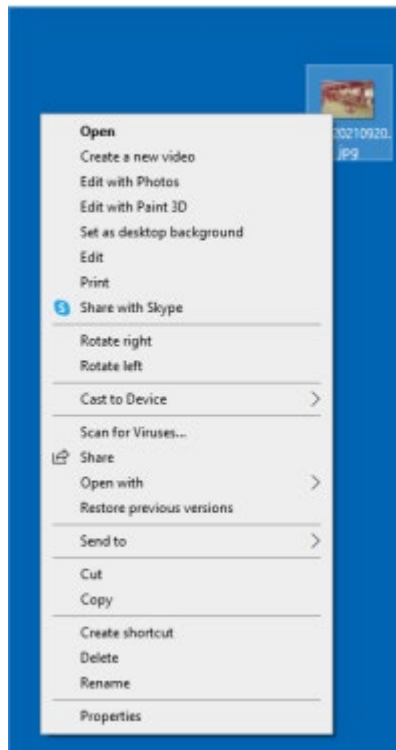

- In the **Details** section, add the Title and other details and comments to your file.

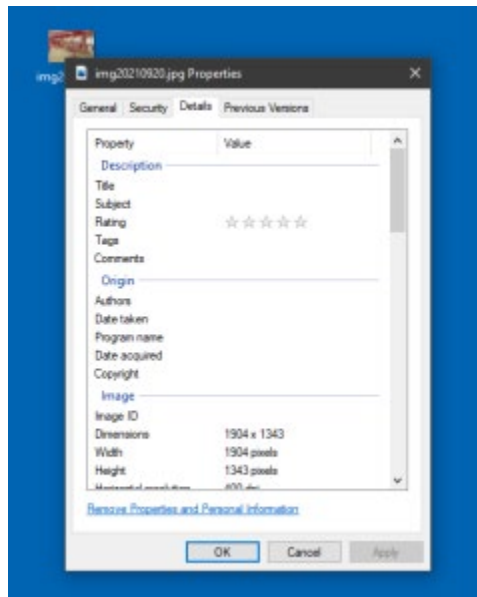

## Step 8: You are done!

- Close out the Preview Screen
- Clean scanning bed with anti-static wipes.
- If you are finished, make sure the scanner is powered off and closed.
- Do not forget to eject your **flash drive or hard drive** and your **photographs**.

## Using the Scanner

### Scanning Documents

#### Step 1: Prepare scanner

- Put on gloves. This way you won't leave prints on the scanner.
- Gently lift the scanner's lid.
- Clean the scanner's surface with an anti-static cloth and air puffer



#### Step 2: Prepare Documents

Note: Make sure the Transparency Unit Mat is in place, there should be a white mat attached to the inside of the scanner's lid. If it is not there, please ask the Memory Lab volunteer for assistance.

- Clean papers gently with anti-static cloth and air puffer.
- Place document face-down on scanning bed.

Note: When scanning newspapers or other thin documents, place black card stock behind the page to prevent bleeding through.

- Be careful not to scratch the scanning bed.
- Gently close scanning bed lid.



#### Step 3: Open Epson Scan

- Make sure that the scanner is powered on.

- Connect your **flash drive or external hard** drive to the computer by USB or USB-C.
- Open the **Epson Scan** icon located on the desktop.

Note: if the icon is not there, search for **Epson scan** and double click on the icon that pops up.

#### Step 4: Settings

- Make sure the Mode is set to **Document Mode**
- Set the Document Source to **Scanner Glass**
- You can decide the other settings as you prefer. If you're not sure, we recommend the following:
  - Image Type: **Black & White** for typed documents, **Color** for handwritten letters
  - Resolution: at least **300** for documents
  - Image Format: **PDF**

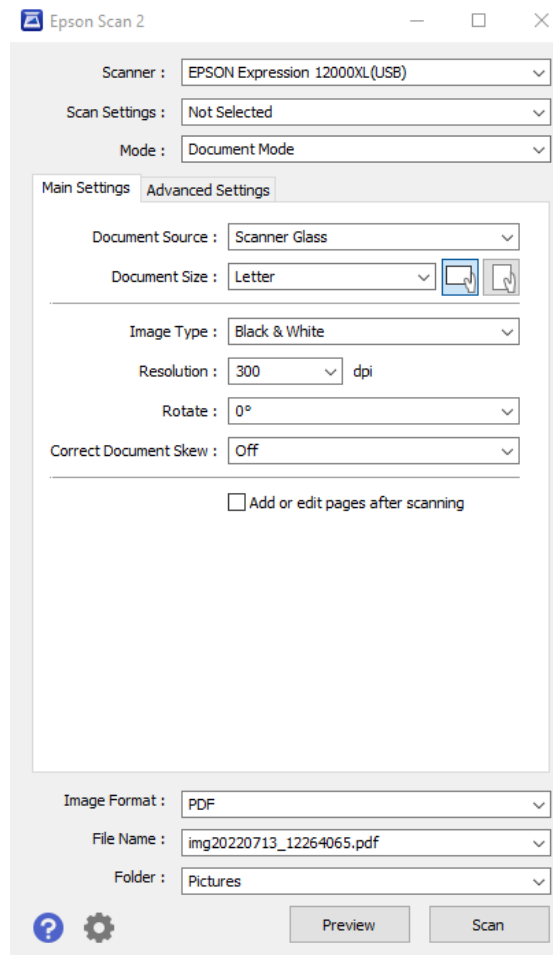

- Click on the **File Name** dropdown list and click **Settings**
- In the **Prefix** box, type your file name.
- Click **OK when** finished



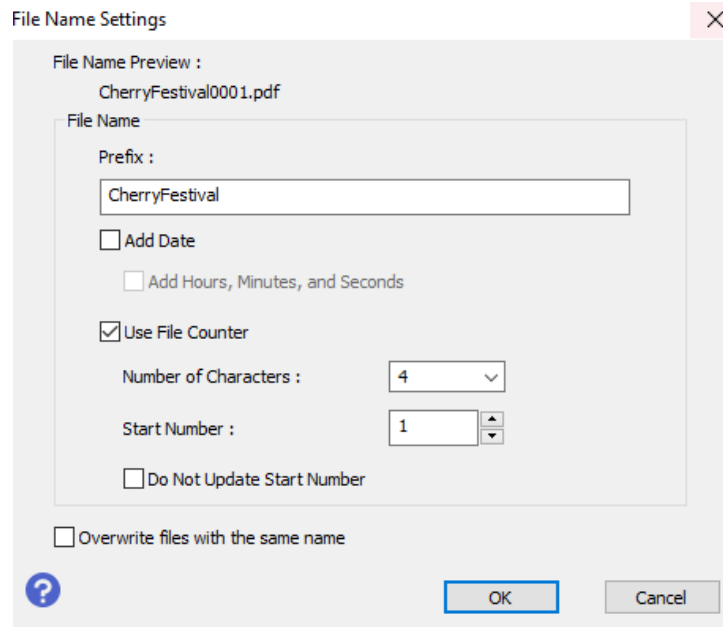

- Click on the **Folder** drop down menu and choose **Select** to find your hard drive or Flash drive from the list. If you are using cloud storage, choose “Desktop”.
- **Optional:** Scanning multiple document? Check the **Add or Edit Pages After Scanning** box to create a PDF file with multiple scans.

### Step 5: Preview and scan

- Click the **Preview** button at the bottom of the main settings window.
- Use the **selection tool (blue crosshairs)** to select the area you want to scan. You can select multiple areas by pressing the Ctrl key simultaneously.
- Use the **Rotate drop down** to change the orientation of the document.

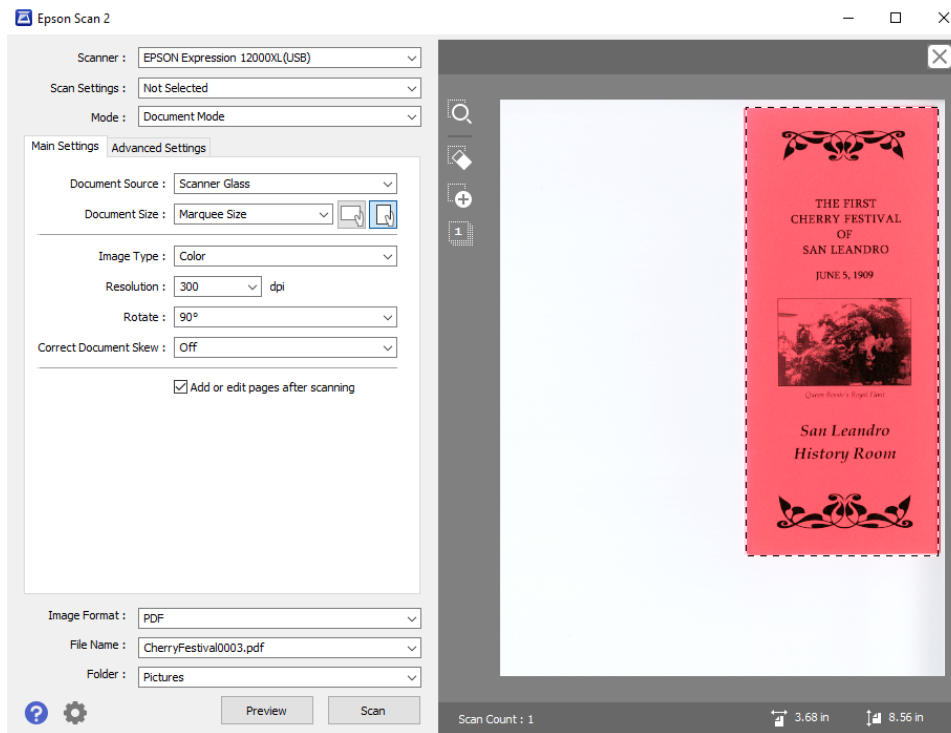

- When finished previewing, click **Scan** at the bottom of the main settings window.

### Step 5a: Scanning two-sided or multiple page documents

- Make sure the **Add or Edit Pages After Scanning** box is checked.
- Click **Scan** to scan the first page.
- Once scanned a new window will pop-up. Flip or change the page to be scanned.
- Click **Add** in the pop-up window to scan the next page.
- Continue adding pages until complete
- Click **Edit** to verify pages.
- Click **Save** for all pages to be saved as a single document.

### Step 6: Add metadata to your files (optional)

- Right-click on one of your finished files and select **Properties** as shown below.

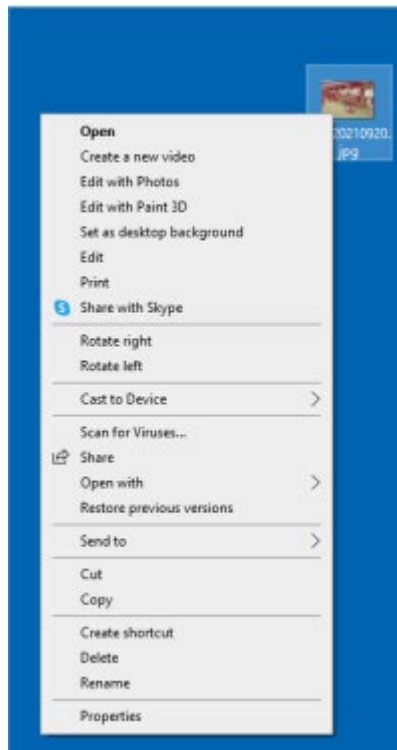

- In the **Details** section, add the Title and other details and comments to your file.

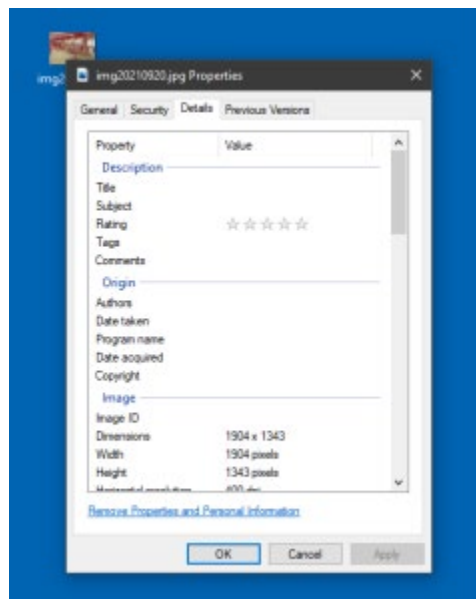

### Step 7: You are done!

- Close out the Preview Screen
- Clean scanning bed with anti-static wipes.
- Make sure the scanner is powered off and closed.
- Do not forget to eject your **flash drive or hard drive** and your **materials**.

## Scanning Negatives & Slides

### Step 1: Prepare scanner

- Put on gloves. This way you won't leave prints on your negatives or slides and scanner.
- Gently lift the scanner's lid.
- Clean the scanner's surface with an anti-static cloth and air puffer.
- You will be using the Transparency Unit for slides

**\*\*Please see volunteer for assistance with removing the white transparency mat on the inside of the scanner's lid\*\***



### Step 2: Prepare the negative or slides

- After the DIY Memory Lab volunteer has removed the Transparency Unit Mat begin to prep your negatives or slides.
- Clean prints and negatives gently with air puffer.
- NEVER touch the negatives with bare fingers.

Note: The scanner can only scan one film holder tray at a time.

## Step 2a: Placing Standard Negative/Film Sizes on the Scanner

- Use the film holders to scan 35mm slides, 35mm filmstrips & negatives, 4 x 5-inch film, and medium format (120, 220, and 16 x 12 cm) film.



- After you choose the correct film holder, place the film holder on a flat surface. Open its cover (if it has one), then load the film with its shiny side face-down.

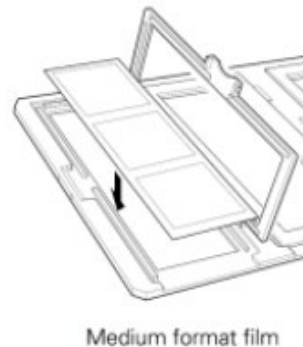
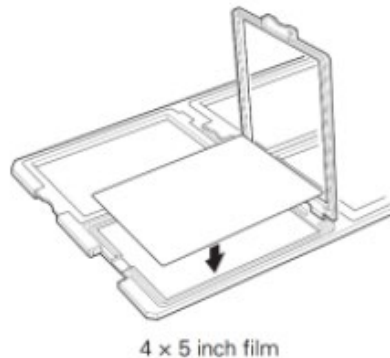
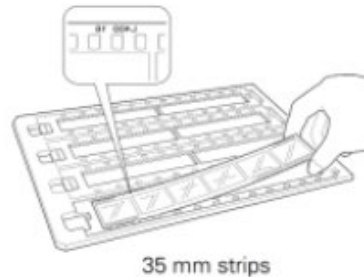
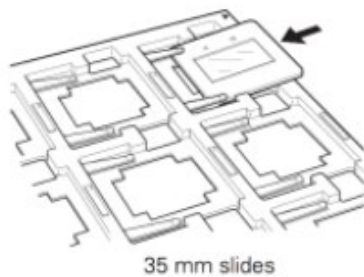

- Place the transparency guide (the skinny rectangular grey plastic piece) at the back edge of the document glass. Then place the film holder on the document glass, aligning the arrow marks. **\*\*Do not slide the holders on the scanner bed. Be careful not to scratch the scanner bed\*\*** See the image below for reference.

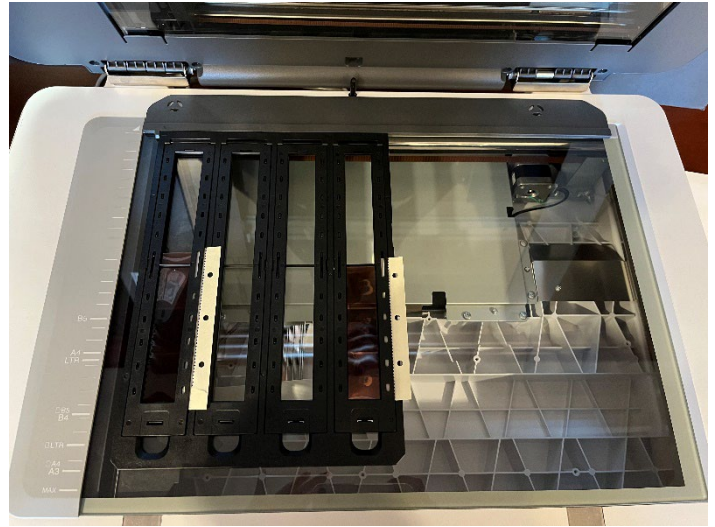
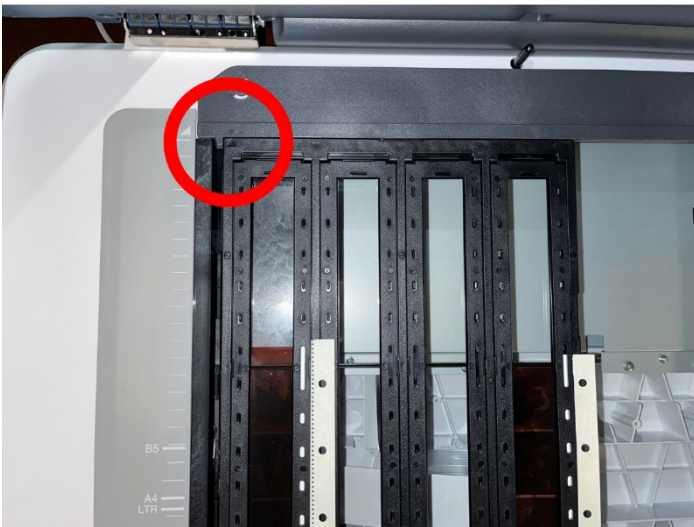

- When scanning a lot of images, you can place a second film holder on the scanner next to the first one.
- Close the scanner lid when film holders are in place.

Note: If you have a non-standard sized film or placed your negatives directed on the glass



### Step 3: Open Epson Scan

- Make sure that the scanner is powered on and is connected to the computer by USB.
- Connect your **external hard drive** or **flash drive** to the computer.
- Open the **Epson Scan icon** on the desktop.

Note: If the icon is not there, search for “Epson Scan” and double click the icon that pops up.

### Step 4: Settings:

- Make sure the Mode is set to **Photo Mode**
- Set the Document Source to **Transparency Unit**
- Set the Document Type to **Color Positive Film** for slides and **Color Negative** or **B&W Negative** for negatives.
- You can decide the other settings as you prefer. If you’re not sure, we recommend the following for 35 mm slides and negatives:
  - Image Type: **24-bit color**
  - Resolution; at least **1800** for slide and negatives (*type in 1800 with keyboard*)
  - Image Format: **TIFF** (archival quality; better for printing & editing) or **JPEG** (for sharing online)

*Note: If you have larger transparencies (larger than 35 mm), we recommend using these recommendations based on the size of your transparency.*

## Film

Long Edge	Recommended DPI
35mm (slides and strips of film)	1800 or higher
3"	1600
4"	1200

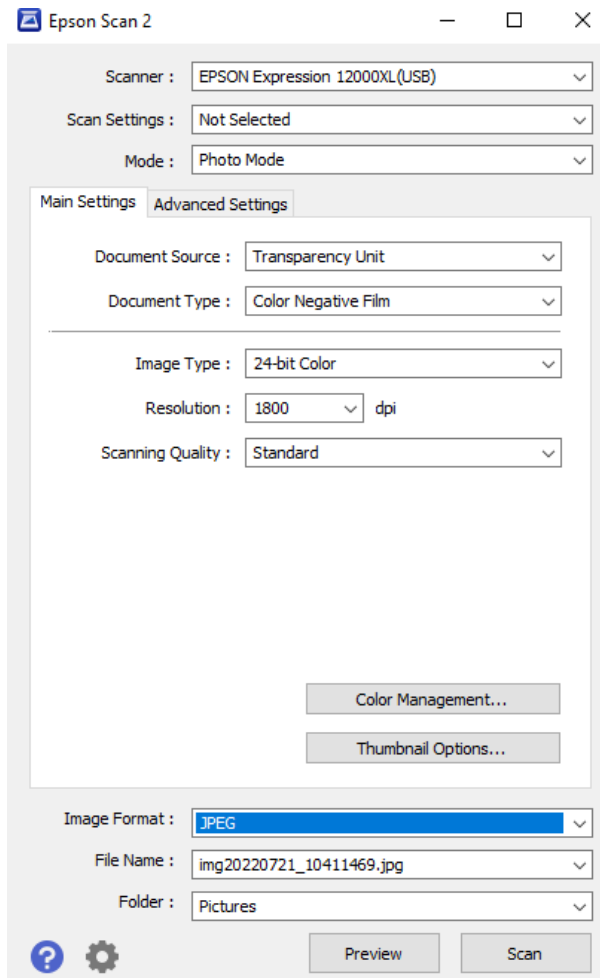

*(This example is for scanning 35mm strips color photo negative)*

## Step 5: File name settings

- Click on the **File Name** dropdown list and choose **Settings**.
- In the **Prefix** box, type your file name. This name will be used for all the slides or negatives scanned in a single batch, with each one followed by a unique number. You can choose the **Number of Characters** that will appear in each number.
- Click **OK** when finished.

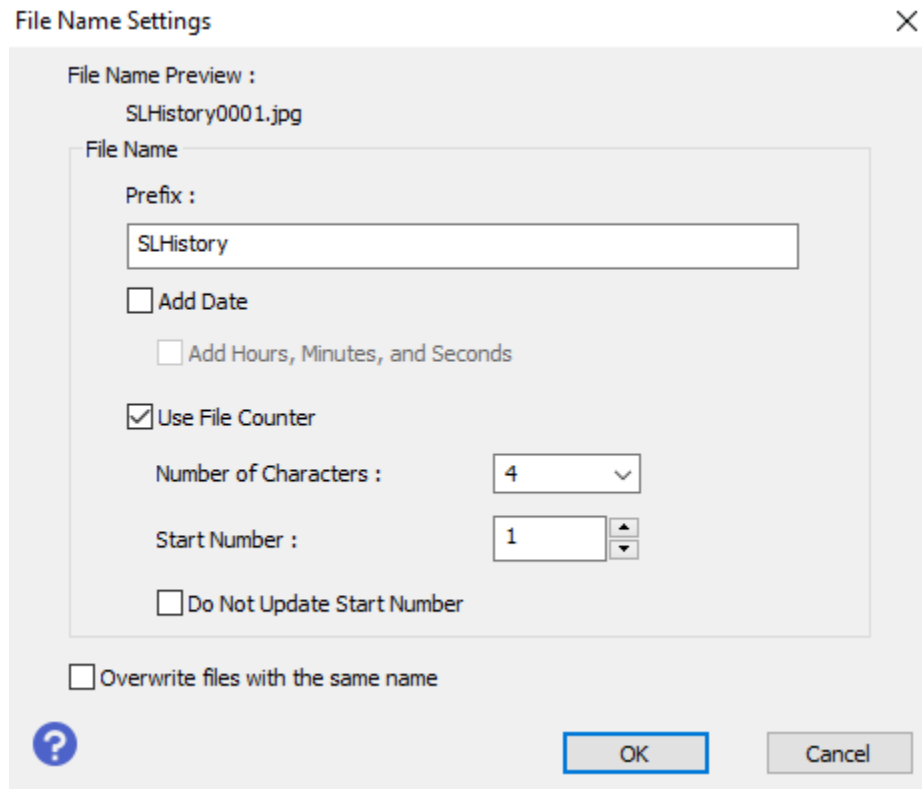



- Click on the **Folder** drop down menu and choose **Select** to find your hard drive or Flash drive from the list. If you are using cloud storage, choose “Desktop”.

## Step 6: Preview and scan

- Click the **Preview** button at the bottom of the main settings window. The scanner should automatically recognize your photographs as separate files. If it does not, make sure the **Thumbnail** setting at the top is selected and click **Preview** again.
- You can use the icons on the left side of the window to rotate or flip each image that you select.

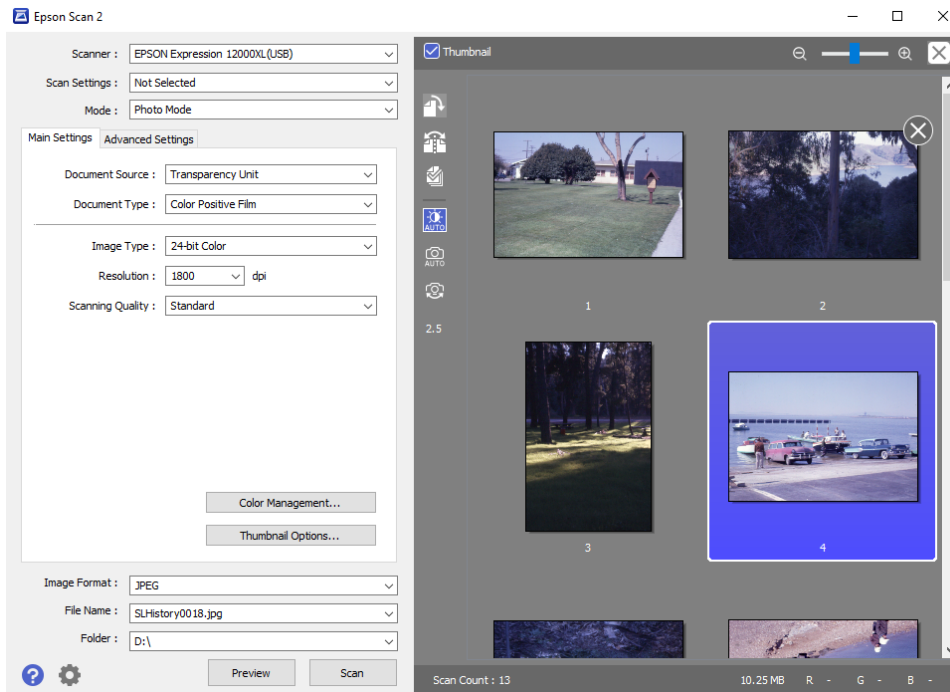



*Note: If you are not using the film holders, use the **selection tool (blue crosshairs)** to select the area you want to scan. Once you select multiple areas, you can scan them all at the same time by clicking “select all” icon  (the number in the middle is dependent on the number of areas you selected).*

- When finished previewing, click **Scan** at the bottom of the main settings window.

## Step 7: Add Metadata to your files (optional)

- Right-click on one of your finished files and select **Properties** as shown below.

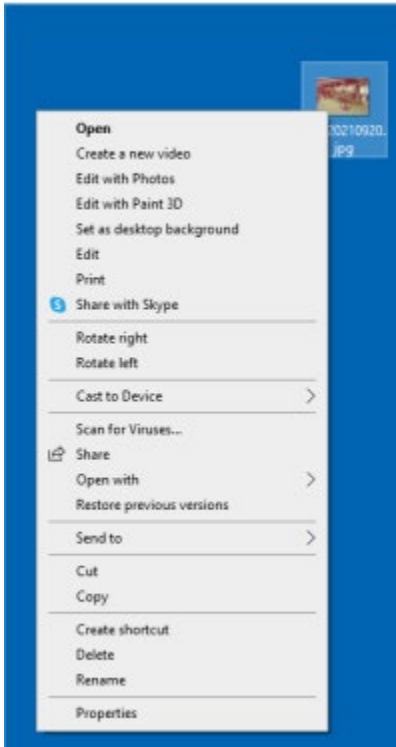

- In the **Details** section, add the Title and other details and comments to your file.

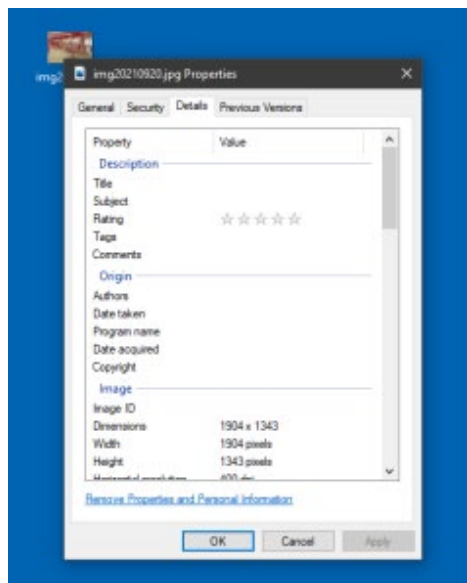

## Step 8: You are done!

- Clean scanning bed with anti-static wipes.
- Make sure the scanner is powered off and closed.
- Do not forget to eject your **flash drive** or **hard drive** and your **materials**.